

SIEMENS

SIWAREX FTC-B

Weighing Module for Belt Scales

Set-up of SIWAREX FTC with SIWATOOL FTC_B

Quick Guide

For modules with order number 7MH4900-3AA01



1 Hardware Requirements.....	3
2 Connections	5
3 SIWATOOL Start.....	8
4 Resolution	9
5 Filter	9
6 Parameters.....	10
7 Calibration	20
8 Material test.....	23
9 Back-up scale adjustments.....	25

Introduction

SIWAREX FTC (Flexible Technology for Continuous Weighing) is a versatile and flexible weighing module for conveyor scales, loss-in-weigh scales and bulk flow meters. It can also be used to record weights and measure force. The SIWAREX FTC function module is integrated in SIMATIC S7/PCS7, and uses the features of this modern automation system, such as integral communication, diagnostics and configuration tools.

Purpose of this document for functional safety

This programming manual contains all information that you will require to commission and use the device.

It is aimed at persons who install the device mechanically, connect it electrically, parameterize and commission it, as well as at service and maintenance engineers.

Notes on warranty

The contents of this programming manual shall not become part of or modify any prior or existing agreement, commitment or legal relationship. All obligations on the part of Siemens AG are contained in the respective sales contract, which also contains the complete and solely applicable warranty conditions. Any statements on the device versions described in the programming manual do not create new warranties or modify the existing warranty.

The content reflects the technical status at the time of printing. We reserve the right to make technical changes in the course of further development.

Validation of this document

This documentation is only valid in conjunction with the manual SIWAREX FTC. This manual is available on the Siemens homepage.

<http://support.automation.siemens.com/WW/view/en/20072206>

1 Hardware Requirements

The following hardware parts and software are required to integrate a scale in SIMATIC: SIWAREX FTC weighing electronic, 24V power supply, S7-300 CPU or ET200M station; memory card for CPU, SIWAREX FTC front connector for SIWAREX FTC, SIWATOOL FTC software, RS232 cable, PC with Windows XP or higher, calibration weight higher than 5% of the sum of the nominal value of all load cells, shield contact element, shield connection terminal.



24V PS



S7-3xx PLC

or



ET 200M



SIWAREX FTC
7MH4900-3AA01



SIWATOOL RS232 cable
7MH4702-8CA



Configuration Package for SIWAREX FTC
For Belt Scales
7MH4900-3AK01



Belt

Idler

Load cell

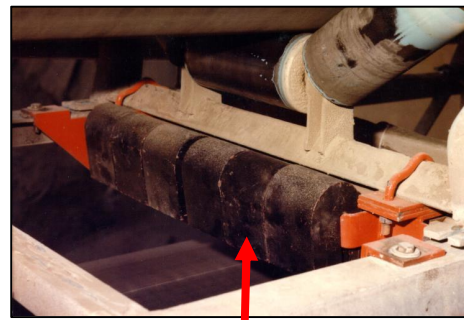

Adjustment weight

Speed Sensor

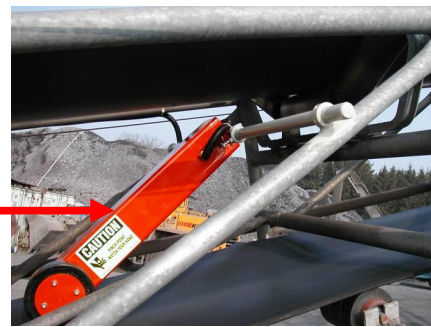

On the internet there is an useful application guidelines with advices how to mount a belt scale:
<http://support.automation.siemens.com/WW/view/en/18246735>

The operating environment shown below includes the following:
 PS207 2A power supply, ET200M Station or CPU3xx, SIWAREX FTC weighing module,
 SIWATOOL cable

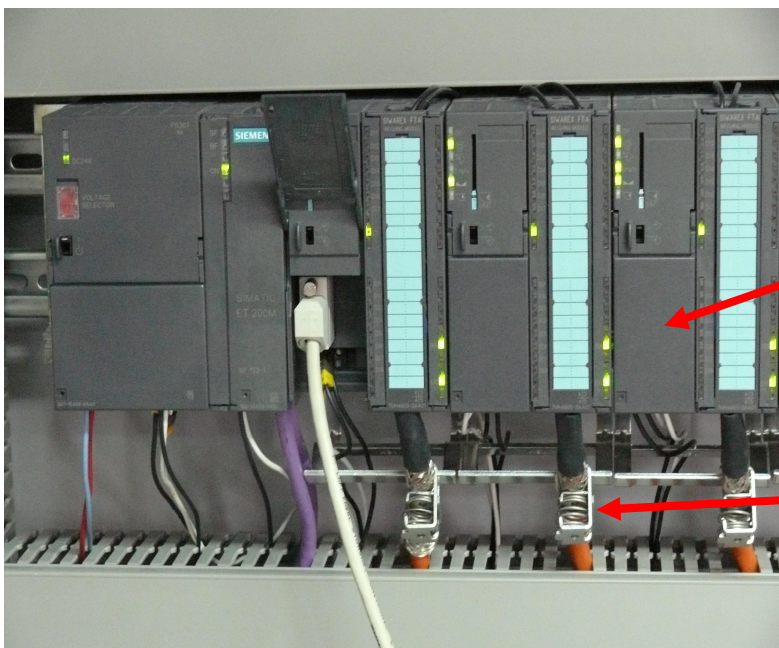

SIWAREX FTC module

Load cell cable

2 Connections

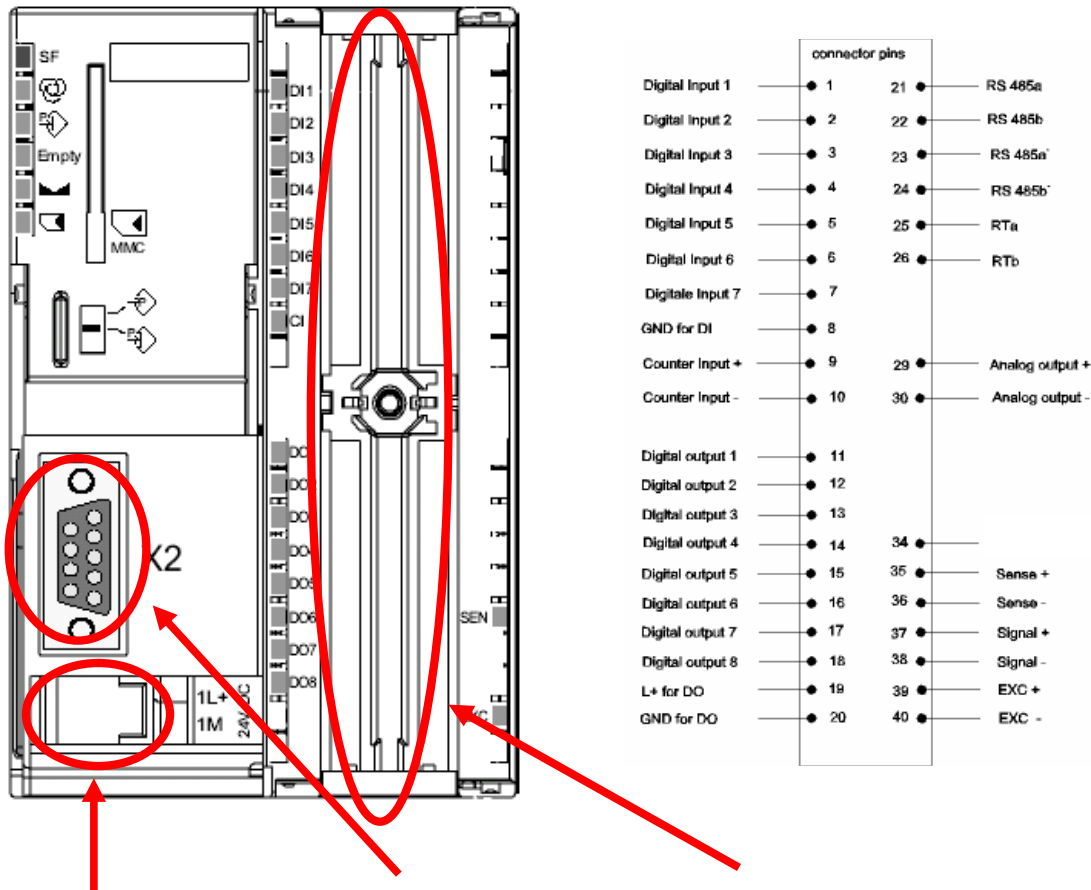

24V Power supply

RS232 interface

Connection terminal of the load cells and speed sensor

Load Cell Connections:

Connection in terminal	Signal	Comment
35	SEN+	Sensor line +
36	SEN-	Sensor line -
37	SIG+	Measurement line +
38	SIG-	Measurement line -
39	EXC+	Load cell supply +
40	EXC-	Load cell supply -

Speed Sensor Connections:

Termination Clamp	Signal	Comment
9	CI+	Counter input +
10	CI-	Counter input -

Circuit diagram (Example) for:

- Belt scale (MUS, MSI, MMI, MLC, MBS, MCS or WD600) with 2 load cells
- speed sensor WS300
- junction box
- Siwarex FTC

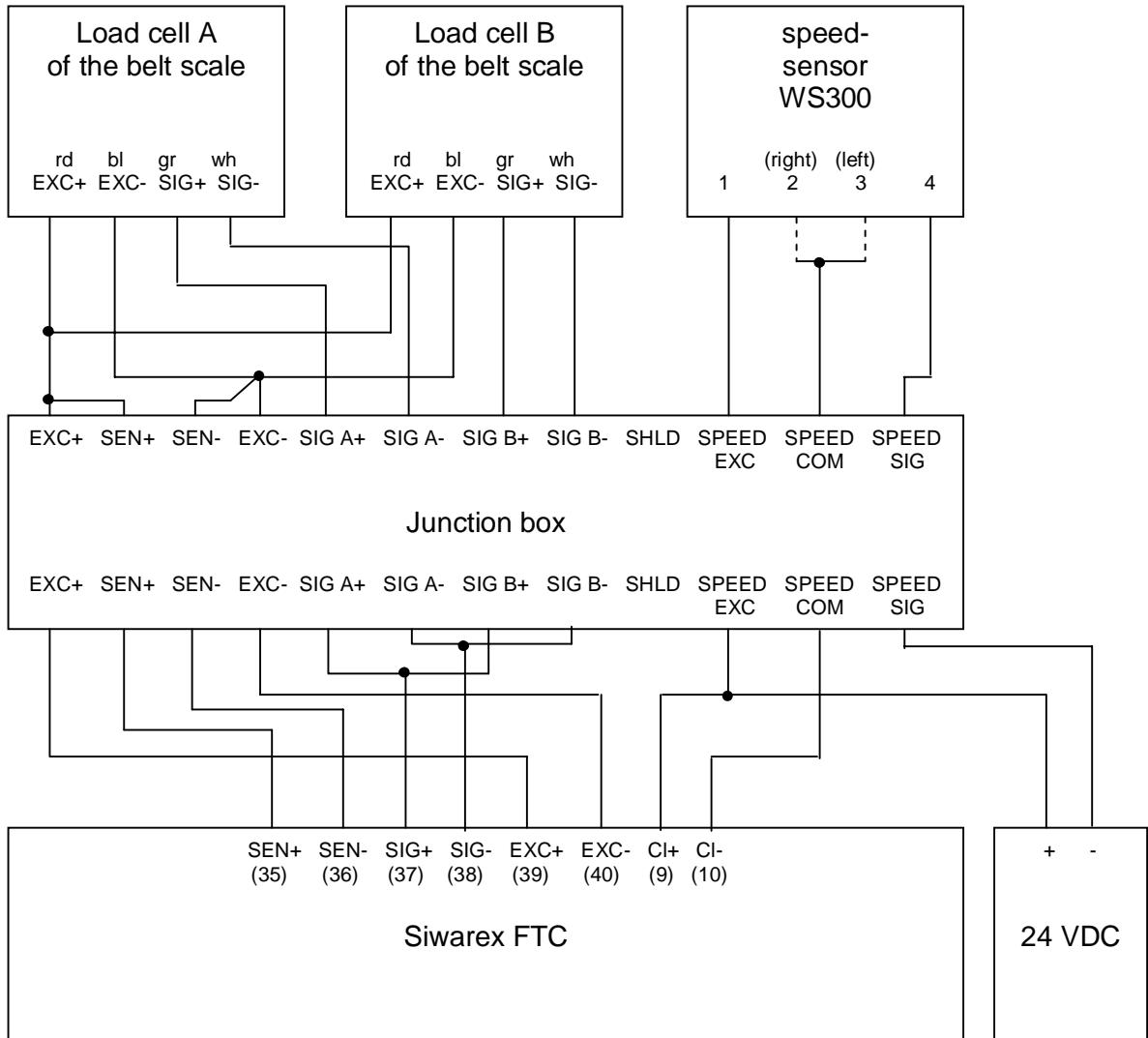

The shield of the load cell cable is connected to ground at the Siwarex FTC module to avoid EMC problems.

That happens with the shield connecting element and the shield connection terminal:

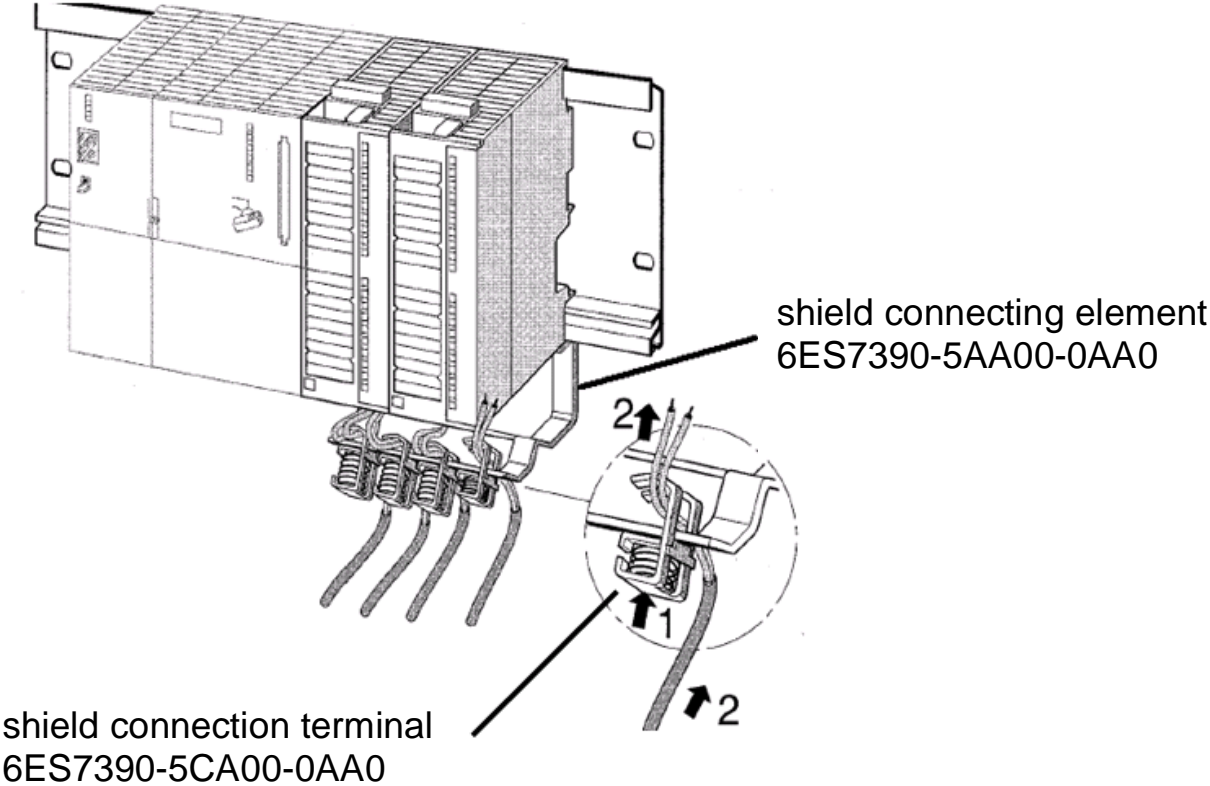

3 SIWATOOL Start

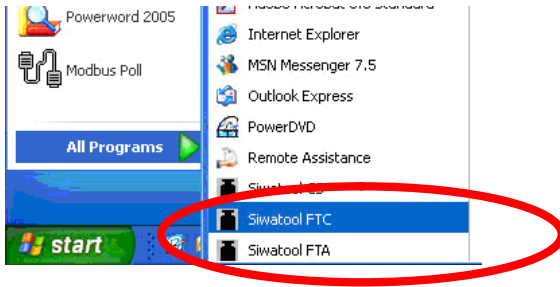

On the SIWATOOL FTC interface, choose the desired interface, which should be the COM used on your computer.

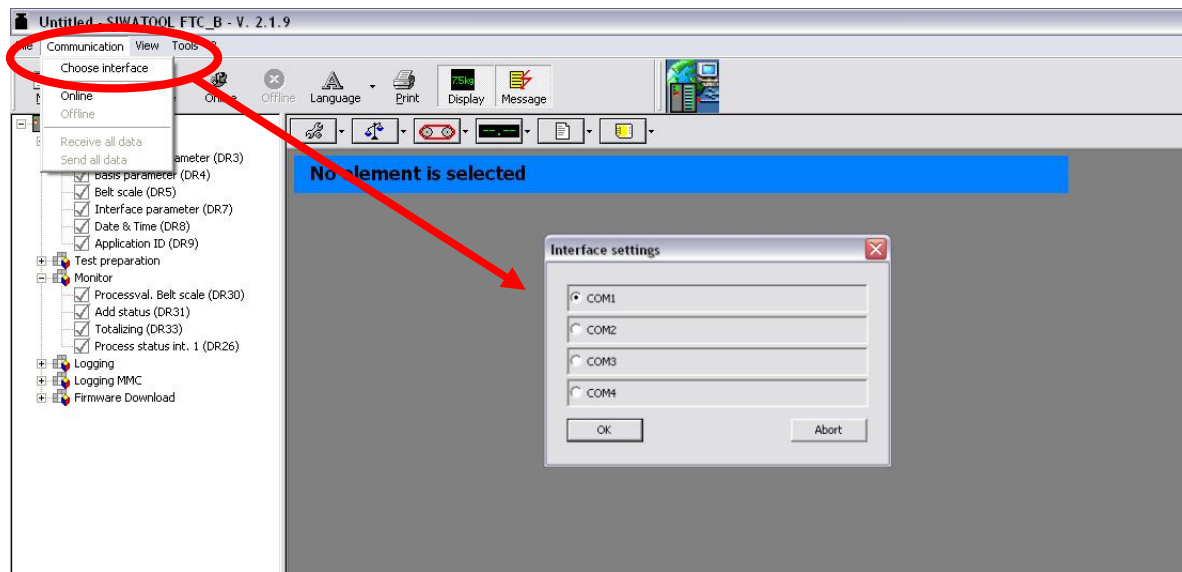

Click „Online“

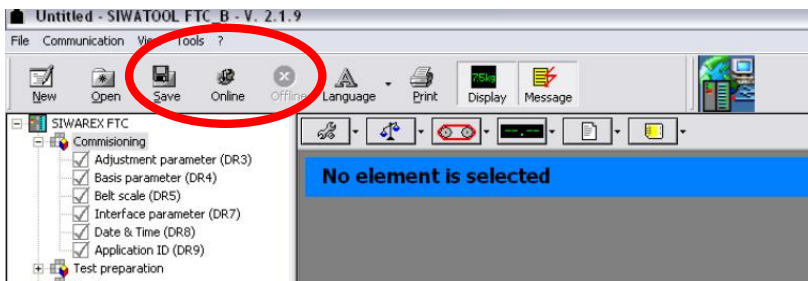

When the communication is established, „Online“ turns grey.

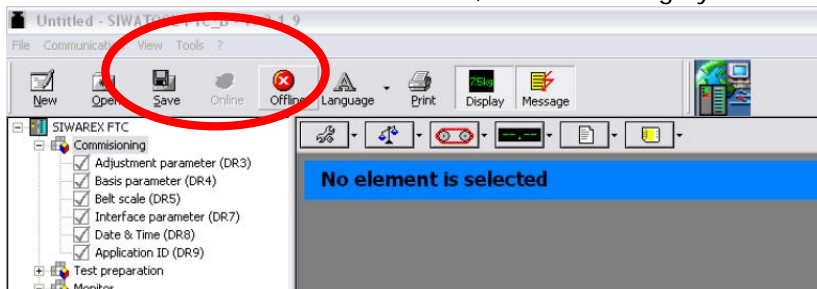

4 Resolution

The Siwarex FTC electronics converts the weight into a 24 bit value.

The value is comprised between approx. 1.4 Mio ... 15.4 Mio Digits. That internal digits value is taken for further calculations, e.g. gross weight, conveyor load and flow rate. These numbers are then transmitted as real values to the SIMATIC PLC.

5 Filter

(Limit frequency: Low-pass filter (0.05 Hz ~ 5 Hz))

Defining the limit frequency is critically important for suppressing interference. The "speed" of scale reaction to the change in measured value is determined by specifying the limit frequency.

If it is set to 2 Hz, the scale will respond quickly to the weight change; if it is set to 0.05 Hz, the scale

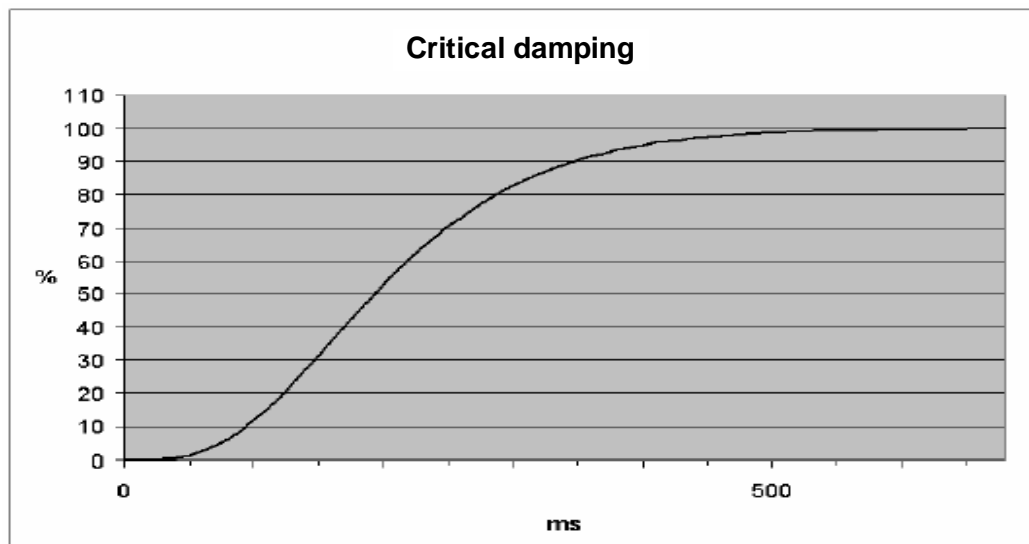

Step response of the digital low-pass filter of 2 Hz

The average value filter ensures a stable weight value and prevents interference. The weight is measured according to the average value of n weight values. If $n = 10$, 10 weight values will be used for calculating the average value. The earliest value is discarded every 10 milliseconds and the recent value will be added for the calculation.

6 Parameters

Before calibrating set the "Service mode on (1)".

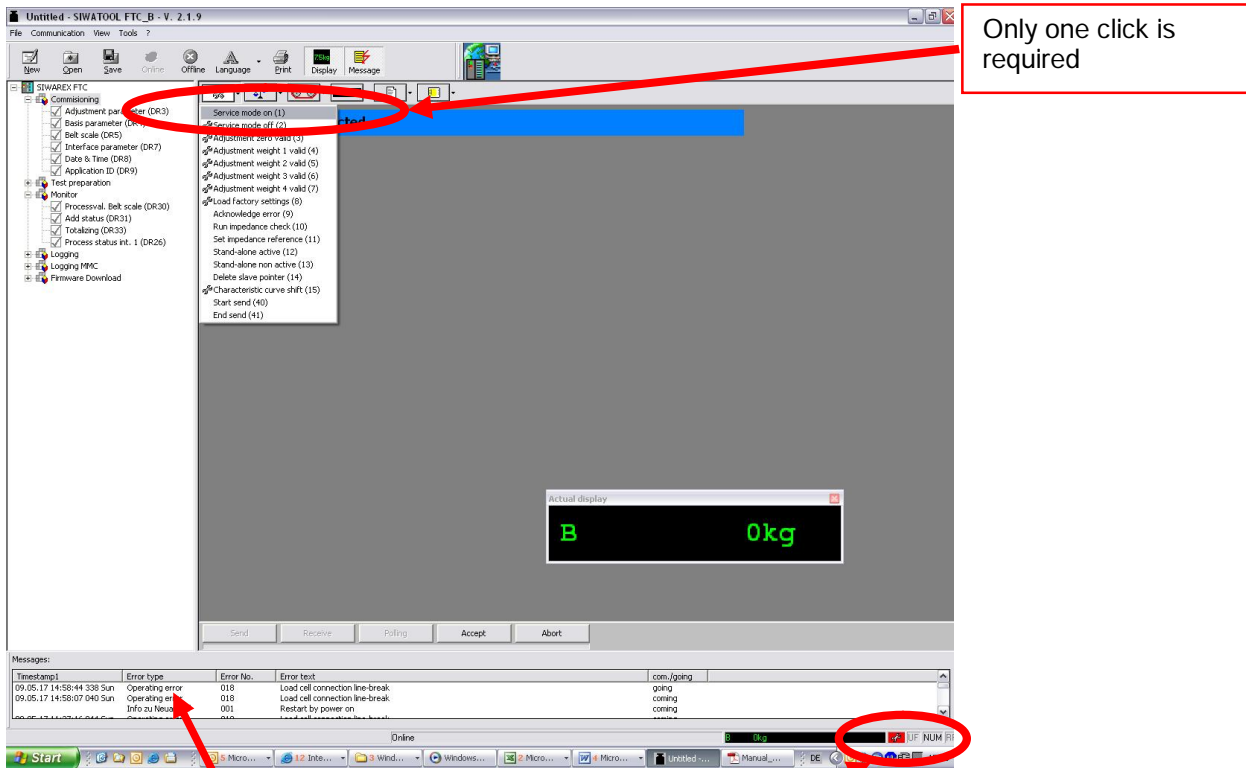

Open "Calibration param.1" under "Adjustment parameter (DR3)", Operating Mode "Belt scale";
Keep all other default values;

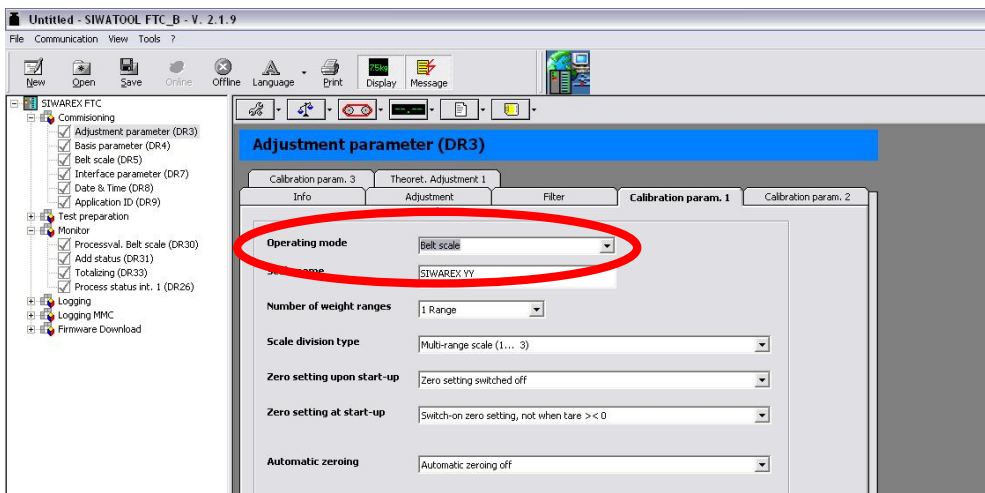

Enter the "Adjustment weight" (e.g. "2.0") and set the "Characteristic value range" depending on load cell; choose "Loading cell type"

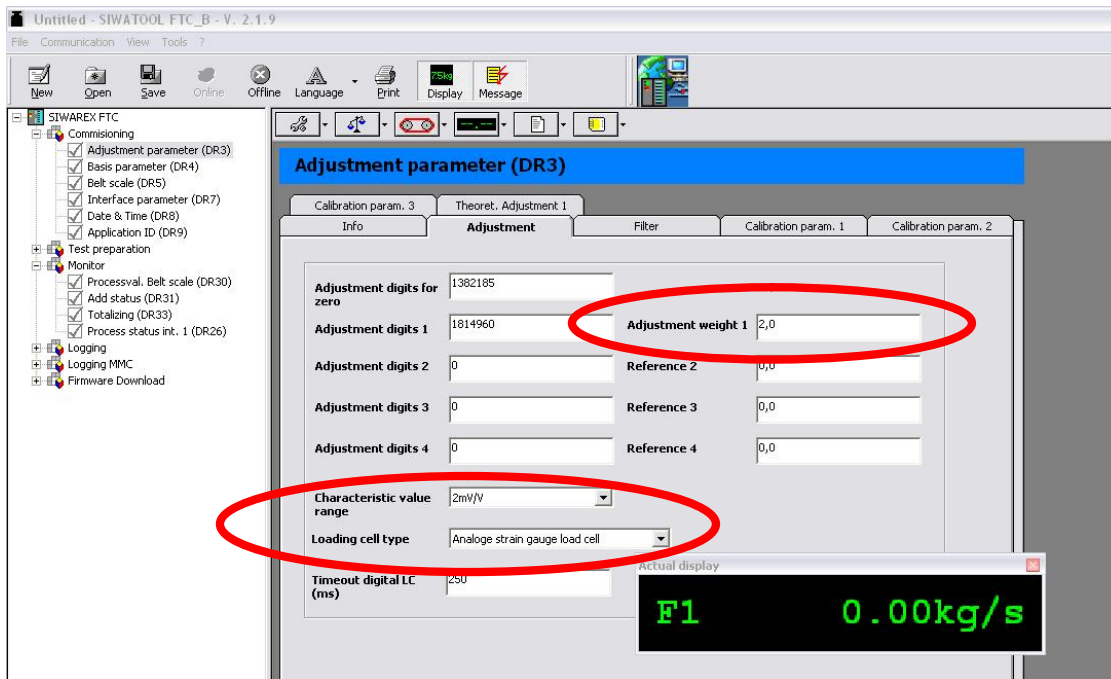

Set parameters "Min/Max weighing range" (Minimum range usually "0") and the "Resolution range 1" in register "Calibration parameter 2".

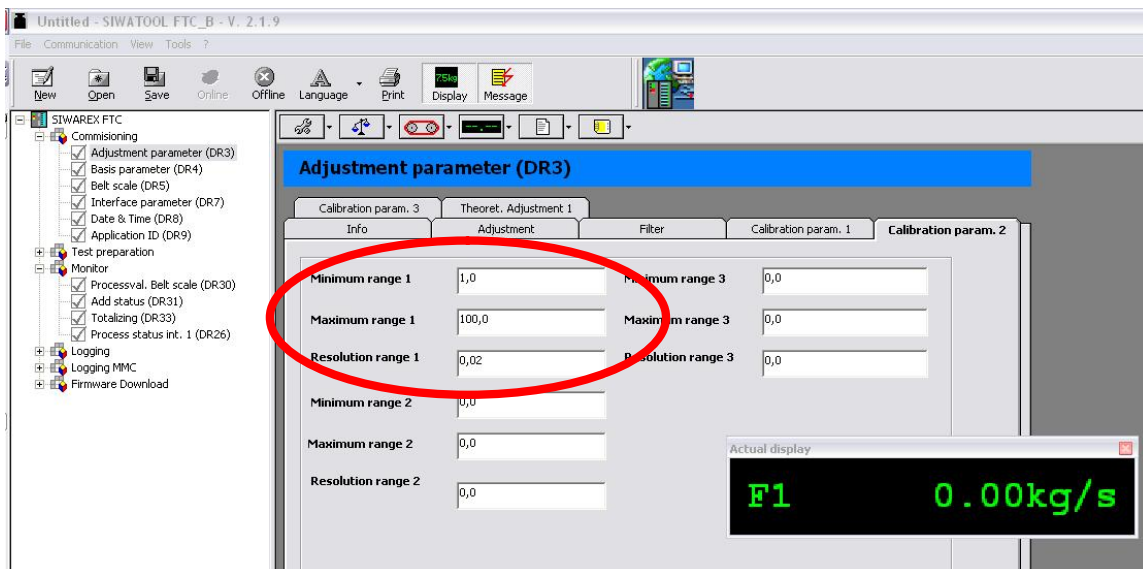

"Resolution range 1": It is the minimum change of the displayed weight. The unit is the same as the **"Weight unit"** selected under the **"Calibration parameter 3"** tab (see below).

Example:

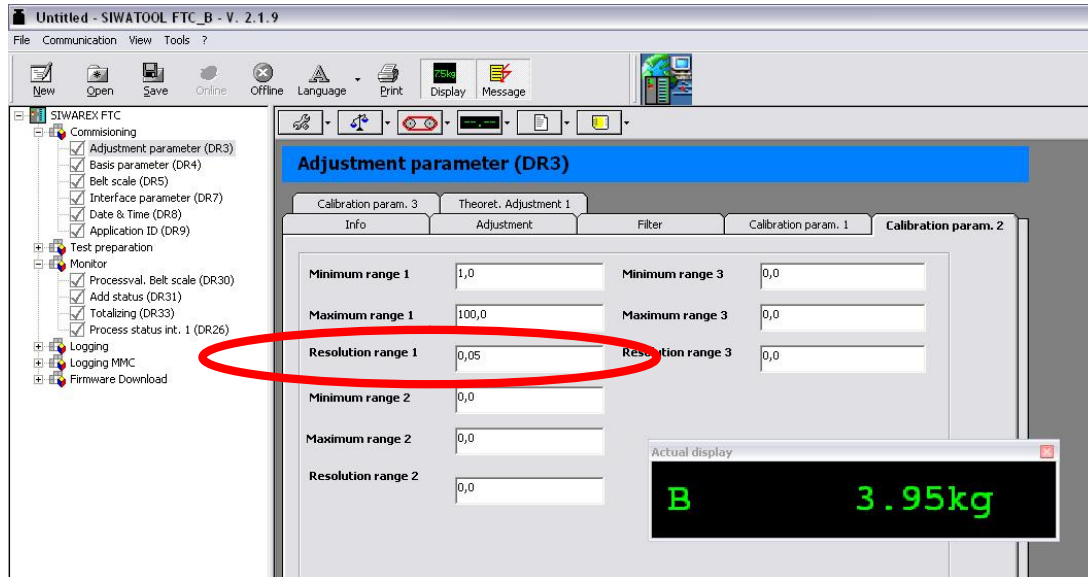

"Resolution range 1" is set to 0.05 kg, so the minimum change is 0.05 kg

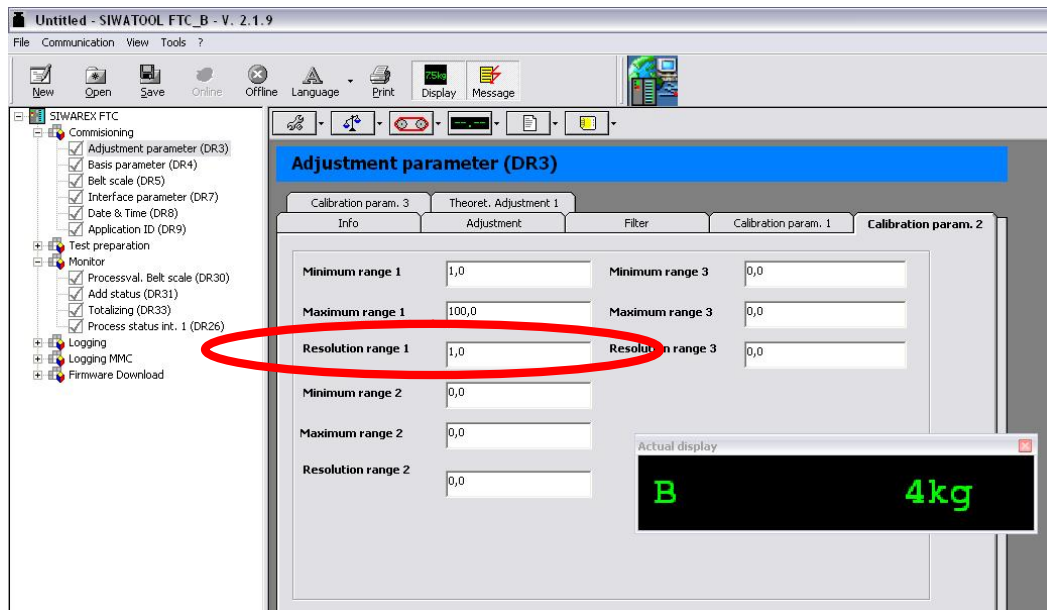

"Resolution range 1" is set to 1.0 kg, so the minimum change is 1 kg

Note: the resolution is related to the weight display and is independent from the weight precision.

Parameter input in register "Calibration param. 3"

Weight unit (e.g.: g, kg, lbs) and Weight unit (large) (e.g.: t)

Length unit in „m“ or „ft“

Time for one belt rotation must be measured and entered into the field „Determination time“

Weight factor = Weight unit (large) / Weight unit

The Determination Time is needed for calibration and zeroing.

The belt may have been repaired and has splices. These mechanical splices create a heavy section that must be taken into account. Also the belt may be not uniform and have a light section

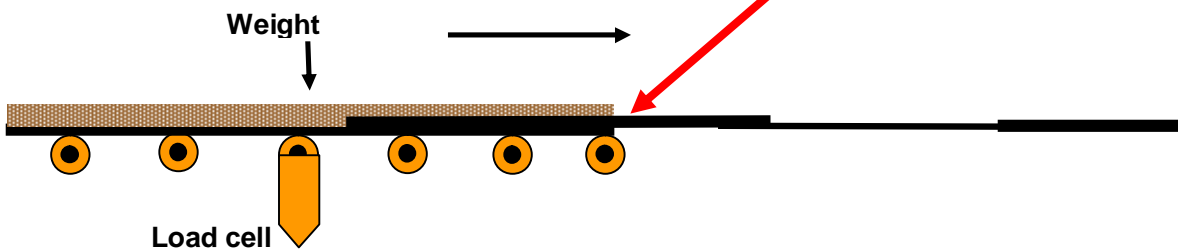

This is why the calibration point is not instantly valid. The average value must be determined over a time period. The "Determination Time" is the period the belt needs for one rotation.

After setting the parameters click



Belt Scale DR5 Register "Belt speed"

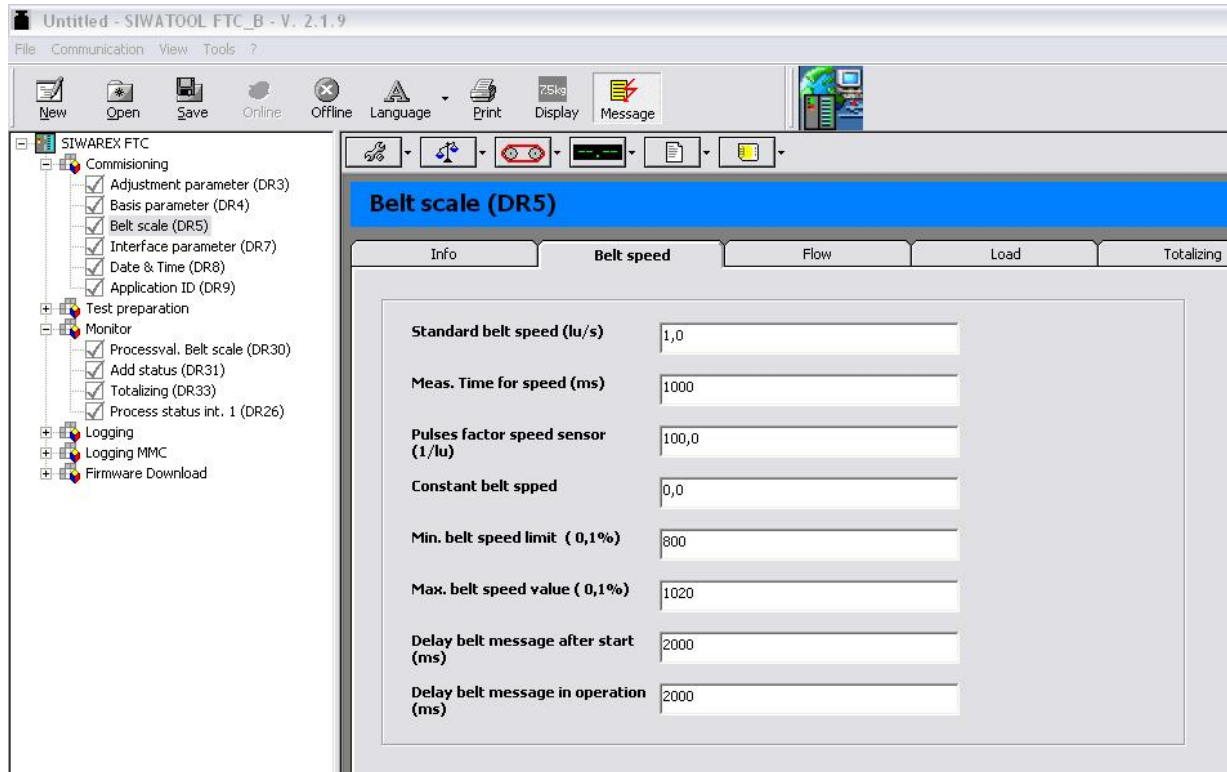

Standard belt speed (lu/s):

The nominal speed of the belt corresponds with the speed at nominal conditions, i.e. at nominal load on the belt. This is output in lu (length units) per second e.g. 1.7 m/sec.

Meas. Time for speed (ms):

The belt speed is defined as output in lu (length units) per second. The measuring time of the pulse input can be set to another time e.g. 2 seconds. The number of pulses given by the speed sensor within this period (Meas. Time for speed (ms)) is added. With it the belt speed is calculated. The speed value output is updated in that case every 2 seconds and the value is shown in DR30 as lu per second.

Pulses factor speed sensor (1/lu):

The pulse constant of the speed sensor indicates the number of pulses per lu (length unit) of the belt. SIWAREX FTC calculates the current belt speed on that base.

Constant belt speed

Constant speed must be defined if no speed sensor is connected. The calculation of the flow-rate is then performed using this value.

When a speed sensor is connected, the value must be set to 0.

Min. belt speed limit (0,1%)

Minimum belt speed is a limit value for minimum belt speed in % of the nominal speed. The entry of the number e.g. 800 corresponds with 80.0 %. After this value has been exceeded SIWAREX FTC sets the status bit ">min. speed" in DR30.

Max. belt speed limit (0,1%)

Maximum belt speed is a limit value for maximum belt speed in % of the nominal speed. The entry of the number e.g. 1020 corresponds with 102.0%. After this value has been exceeded SIWAREX FTC sets the status bit ">max. speed" in DR30.

Delay belt message after start (ms)

Monitoring the belt speed is only activated after this delay time when the belt is started.

Delay belt message in operation (ms)

When the minimum belt speed is fallen short, the message or status bit is only activated after this delay time has elapsed.

Belt Scale DR5 Register "Flow"

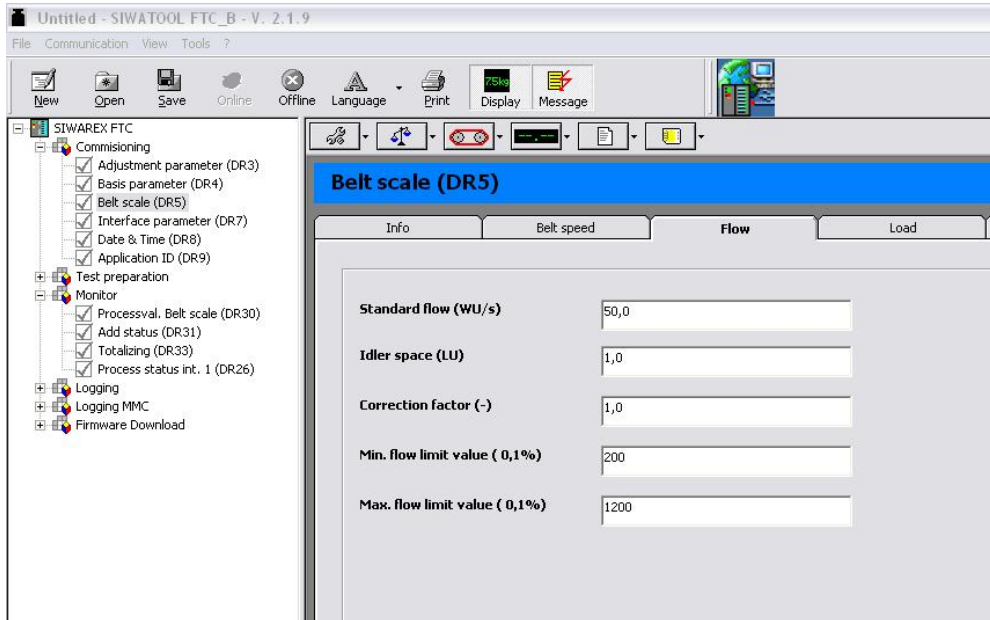

Standard flow

Nominal flow-rate is defined as WU (weight units) / sec and is determined by the user. It corresponds with the flow-rate that the belt is equipped for.

Idler space

Effective belt length is defined as length units LU. The effective belt length corresponds with half of the distance between the belt rollers which are found before and after the roller with the belt scale. The effective belt length is calculated as follows:

For scales with one idler:

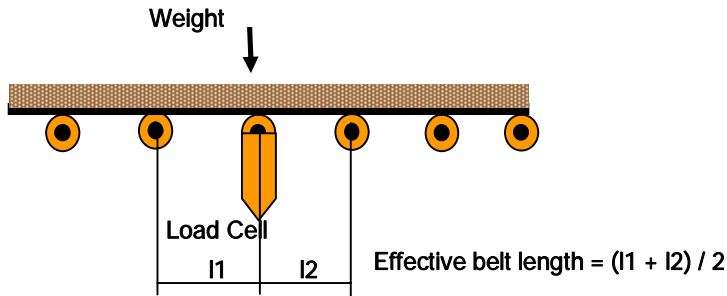

For scales with two idler:

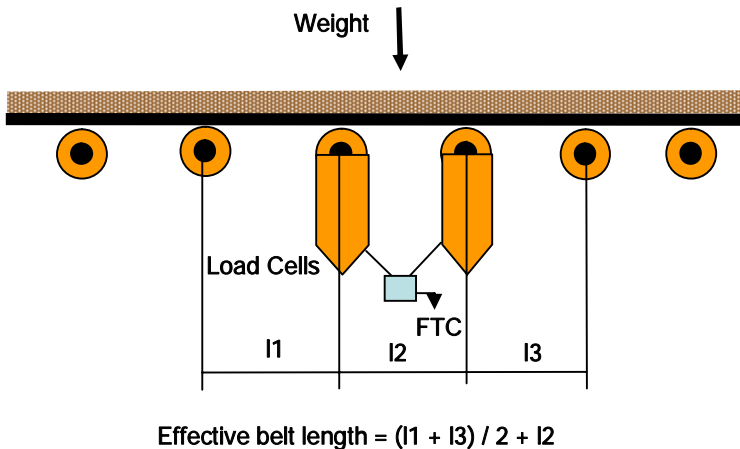

Correction factor

A material test can be performed to compare the actual required material quantity with the total calculated by SIWAREX FTC. A correction factor can be defined for the calculation of the flow-rate quantity for small deviations.

=> **correction factor = material weight / totalizer**

Min. flow limit value

Minimum flow-rate is a limit value for minimum flow-rates in % of the nominal flow-rate. The entry of the number e.g. 800 corresponds with 80.0%. After this value has been fallen short SIWAREX FTC sets the status bit ">min. flow" in DR30.

Max. flow limit value

Maximum flow-rate is a limit value for maximum flow-rates in % of the nominal flow-rate. The entry of the number e.g. 1020 corresponds with 102.0 %. After this value has been exceeded SIWAREX FTC sets the status bit ">max. flow" in DR30.

Belt scale DR5 Register "Load"

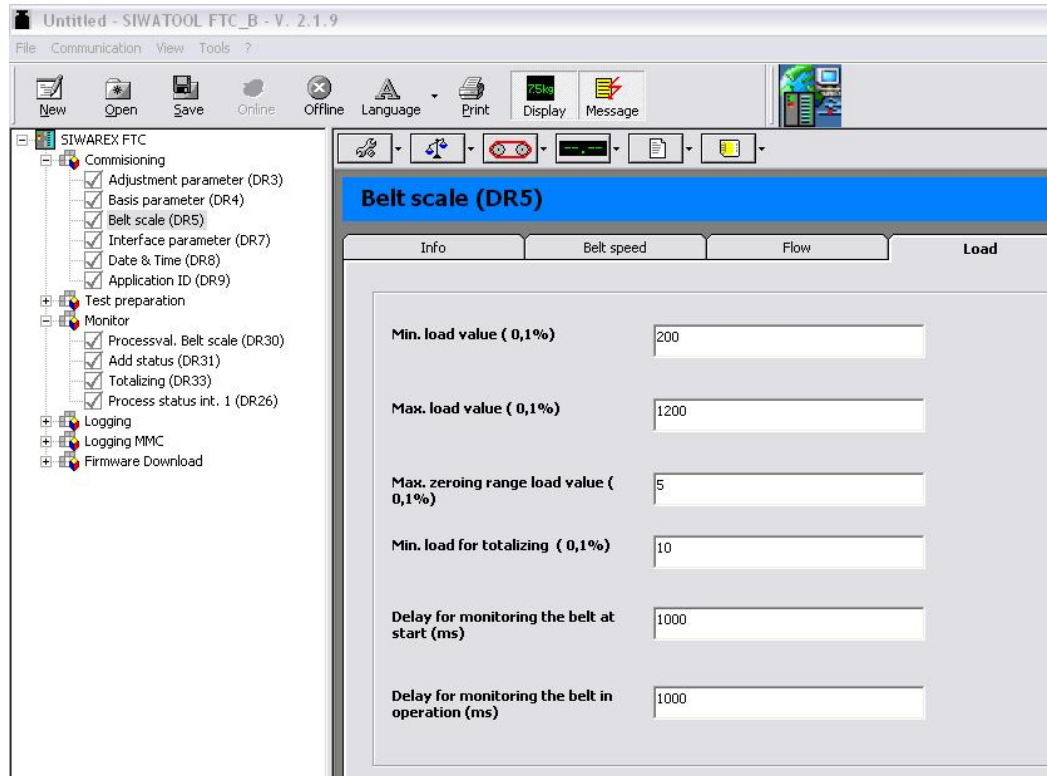

Min. load value

Minimum belt loading is a limit value for minimum belt loading in % of the nominal belt loading. The entry of the number e.g. 800 corresponds with 80.0 %. After this value has been exceeded SIWAREX FTC sets the status bit ">min. load" in DR30. In batch mode the totalizing will be completed after the dosing signal is switched off and the belt load is less than this limit value.

Max. load value

Maximum belt loading is a limit value for maximum belt loading in % of the nominal belt loading. The entry of the number e.g. 1020 corresponds with 102.0 %. After this value has been exceeded SIWAREX FTC sets the status bit ">max. load" in DR30.

Max. zeroing range load value (0,1%)

Maximum belt loading for zero setting is a limit value for maximum belt loading in % of the nominal belt loading. Entering the number e.g. 20 corresponds with 2.0 %. After this value has been exceeded SIWAREX FTC will not execute the zero setting instruction.

Min. zeroing range load value (0,1%)

Minimum belt loading for totalizing is a limit value for minimum belt loading in % of the nominal belt loading. Entering the number e.g. 20 corresponds with 2.0 %. After the actual value is less than the limit SIWAREX FTC will not execute the totalizing function.

Delay for monitoring the belt at start (ms)

After the belt is switched on, undercutting the minimum belt loading or the minimum flow-rate is only indicated after this time has elapsed.

Delay for monitoring the belt in operation (ms)

After the minimum belt load has been undercut or the minimum flow-rate is undercut the respective message or status bit is output only after this time has elapsed.

Belt Scale DR5 Register "Totalizing"

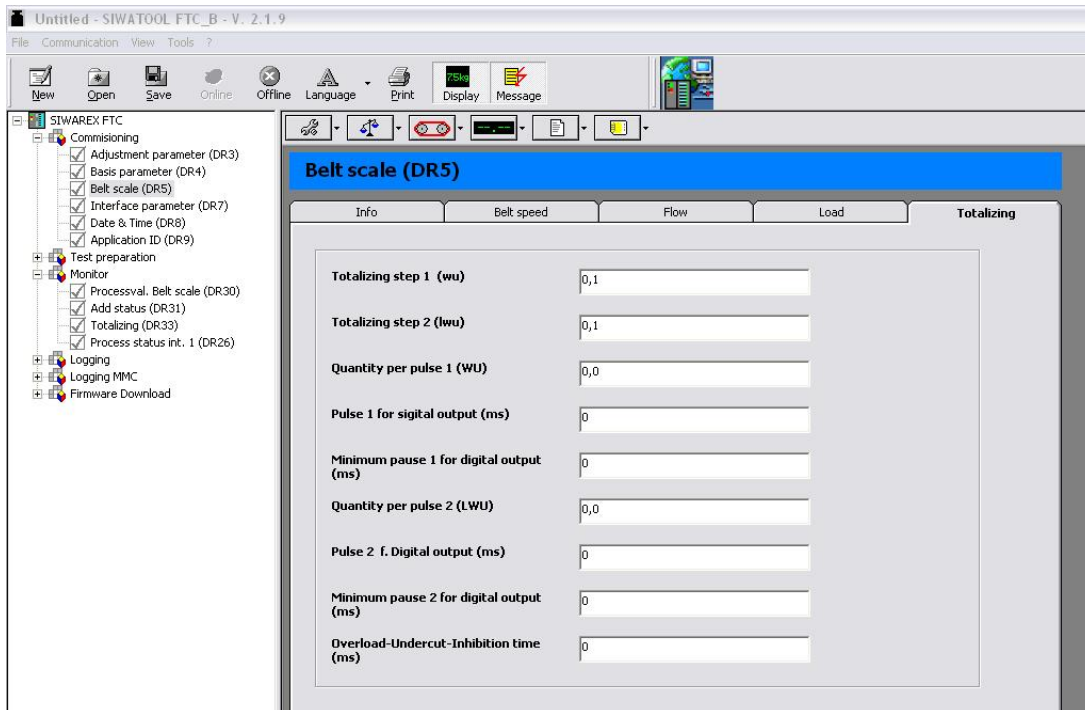

Totalizing step 1 (wu)

The totalizing memory 1...4 is run with the weight unit indicated in data record 3. The user can define the smallest step for creating a total with the numeral step.
E.g. weight unit 1 kg, numeral step for creating the total can be 5 kg.

Totalizing step 2 (lwu)

Totalizing memory 4...8 is run with large weight unit indicated in data record 3. The user can define the smallest step for creating a total with the numeral step.
E.g. Weight unit 1 kg, numeral step for totalizing can be 1 t.

Quantity per pulse 1 (wu)

The material quantity per pulse 1 indicates after which quantity increase of totalizing memory 1.....4 should output a pulse through the defined digital output.

Pulse 1 for digital output (ms)

For the external quantity counter the pulse duration can be defined so that the device can recognize the pulse for sure. The pulse duration is not permitted to be selected so long that stopping the minimum pause duration will make the next pulse late.

Minimum pause 1 for digital output (ms)

For the external quantity counter the minimum pause can be defined. The minimum pause is not permitted to be selected so long that stopping the minimum pause duration will make the next pulse late.

Quantity per pulse 2 (lwu)

The material quantity per pulse 2 indicates after which quantity increase of totalizing memory 5.....8 should output a pulse through the defined digital output.

Pulse 2 for digital output (ms)

For the external quantity counter the pulse duration can be defined so that the device can recognize the pulse for sure. The pulse duration is not permitted to be selected so long that stopping the minimum pause duration will make the next pulse late.

Minimum pause 2 for digital output (ms)

For the external quantity counter the pulse duration can be defined so that the device can recognize the pulse for sure. The pulse duration is not permitted to be selected so long that stopping the minimum pause duration will make the next pulse late.

Overload-Undercut-Inhibition time (ms)

When falling short or exceeding the load cell signal a fault is indicated. For the defined inhibition time, the fault message is suppressed. If the status remains for a longer period of time the fault message is output.

Belt Scale DR14 Register "Tilt angle"

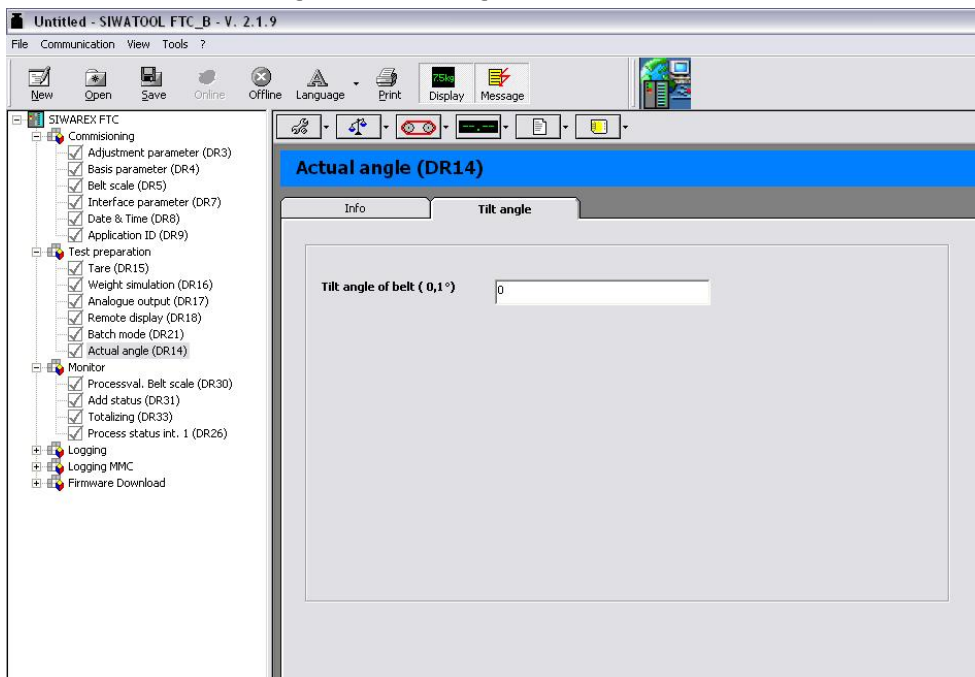

Tilt angle of belt (0,1%)

DR 14 is used for an external definition of the belt tilt angle. If the belt is mounted horizontally, the definition is 0. The belt can be tilted to a maximum of 60°.

Always ensure that the definition corresponds with the current tilt angle, otherwise the belt load will be calculated incorrectly.

After setting the parameters, click **Send**.



7 Calibration

Set display to „Show weight (140)“

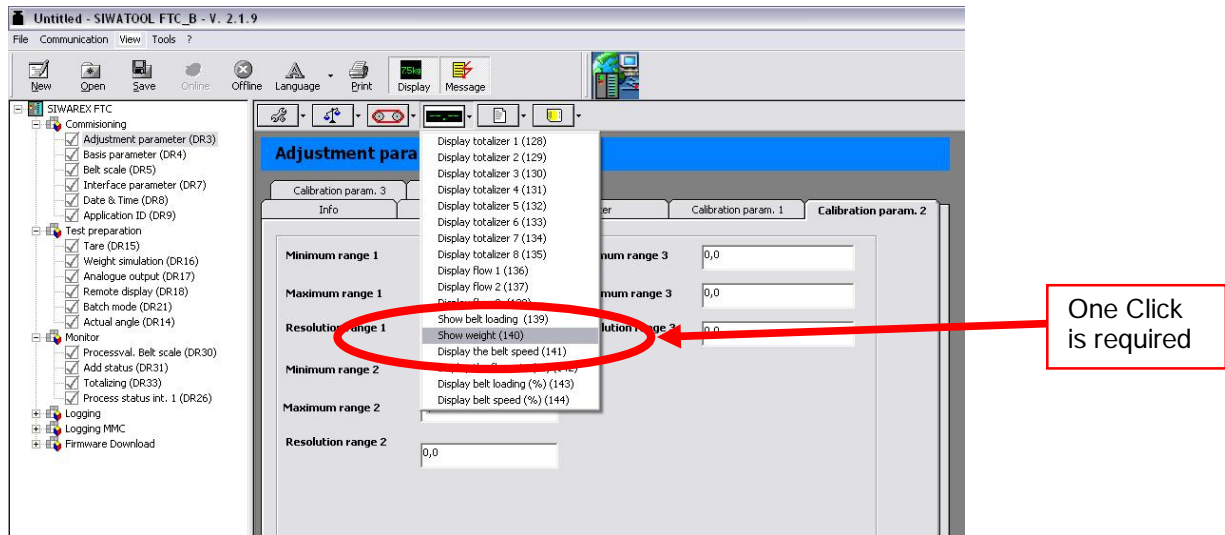

Switch on the belt
Click „Belt on (100)“

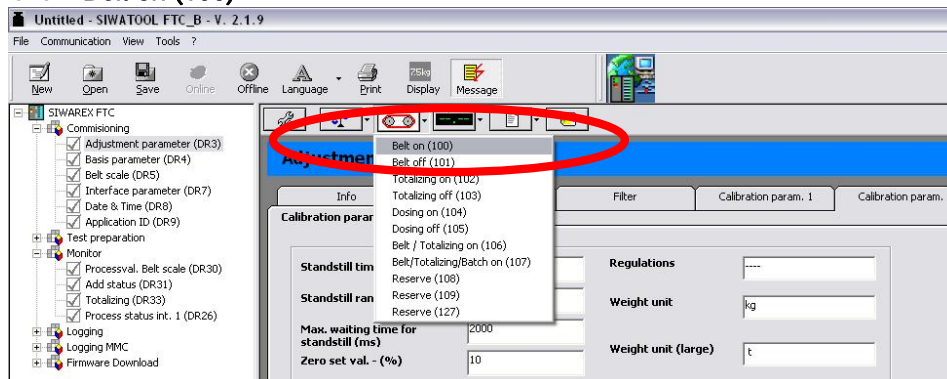

Ensure that the belt is empty (not loaded) and click „Adjustment zero valid (3)“.

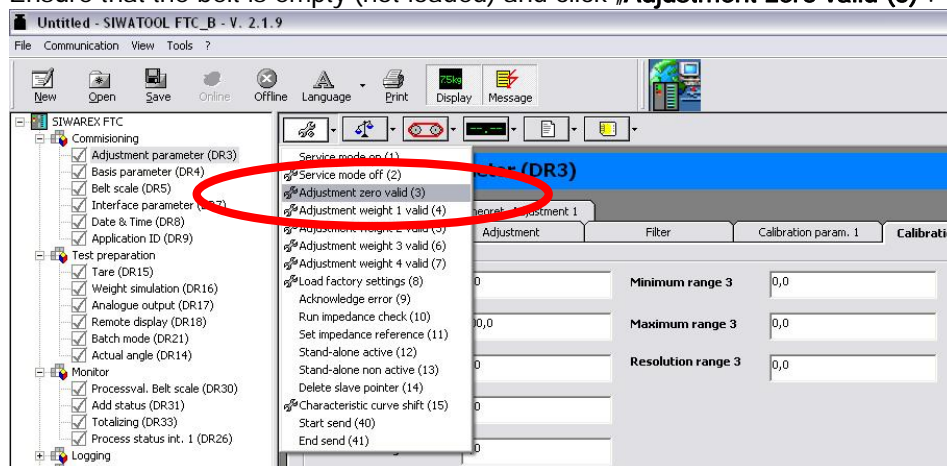

During the determination time elapses the status bit in DR 30 "Dynamic command on" is set.

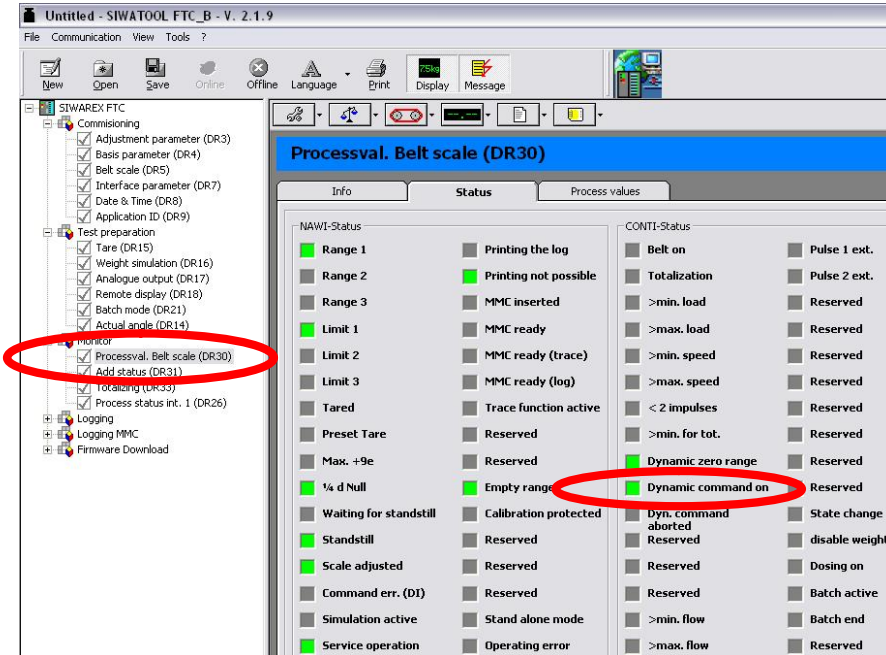

After executing the command the display shows following value:



Load the calibration weight onto the scale (the display could be different currently) and click "Adjustment weight 1 valid (4)"

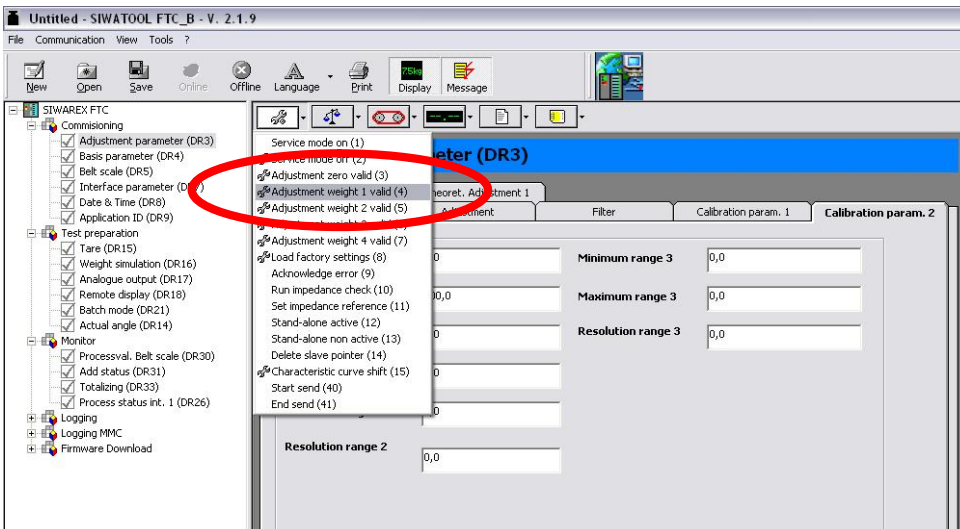

During the determination time elapses the status bit "Dynamic command on" in DR30 is set.

After the determination time the display shows the values of the calibration weight.



Afterwards set the "Service mode off (2)"

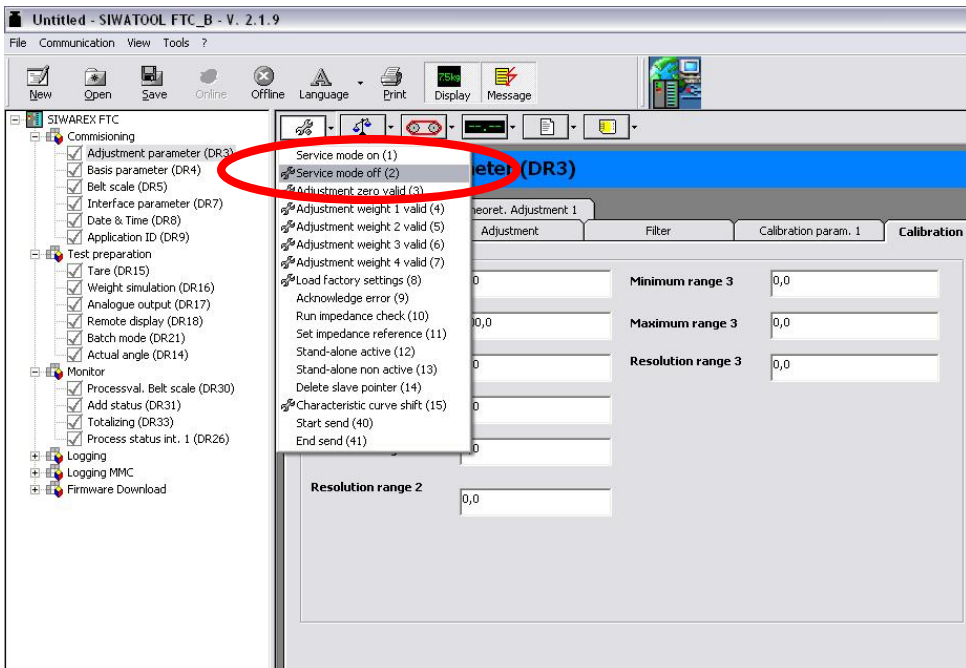

8 Material test

Configuration

The following sketch shows test equipment using a pre-weighed and loaded truck. In that case the truck scale is used as a reference for the belt scale.

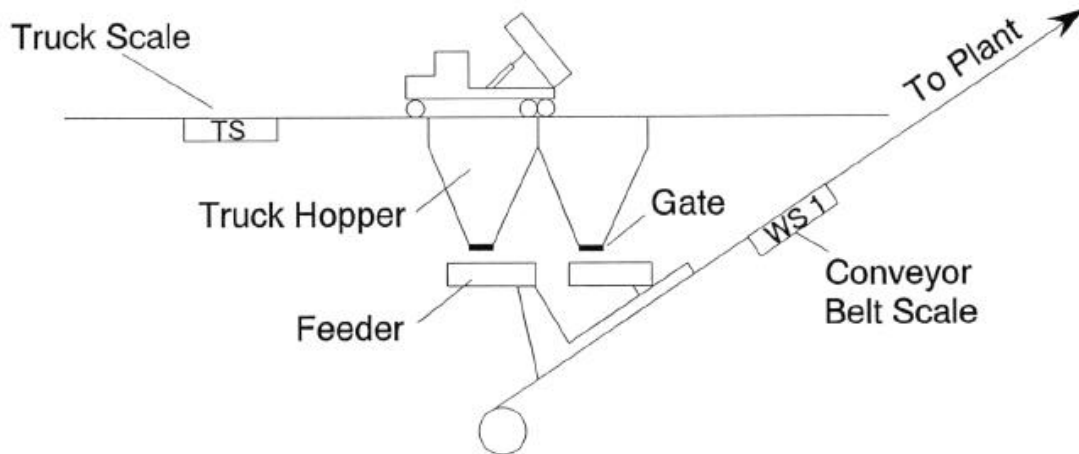

Totalizing

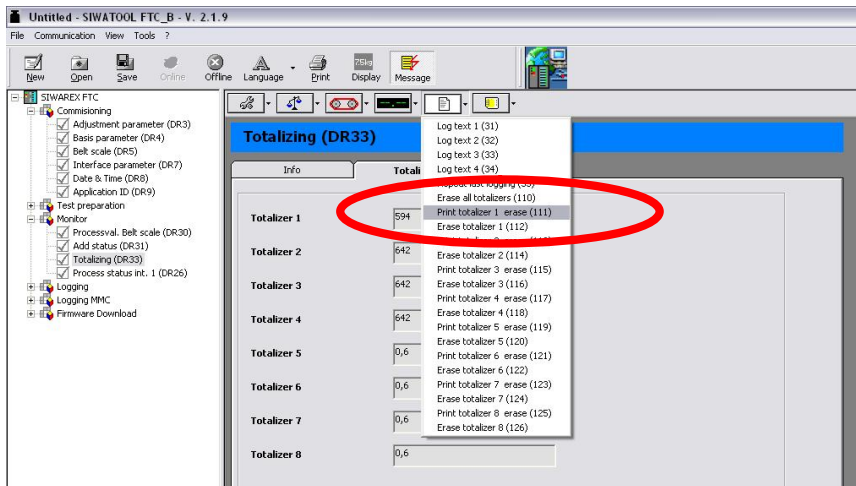

Totalizing is performed at the same time for every distribution memory location. The user can delete a certain location at any time which defines the totalizing period.

e.g. Totalizer 1

Content of distribution memory. Dimension in weight units [WU]. Can be reset with instruction „Erase totalizer 1“ or „Print totalizer 1 erase“.

Determination of the flow deviation

By a material check the actual raised material quantity could get compared to the quantity calculated by SIWAREX FTC. For small deviations the calculation of the discharge could be influenced through a correction factor

The deviation could get calculated as follows:

$$\text{Correction Factor} = (\text{Material weight of the material check} / \text{Totalizer of the Siwarex FTC})$$

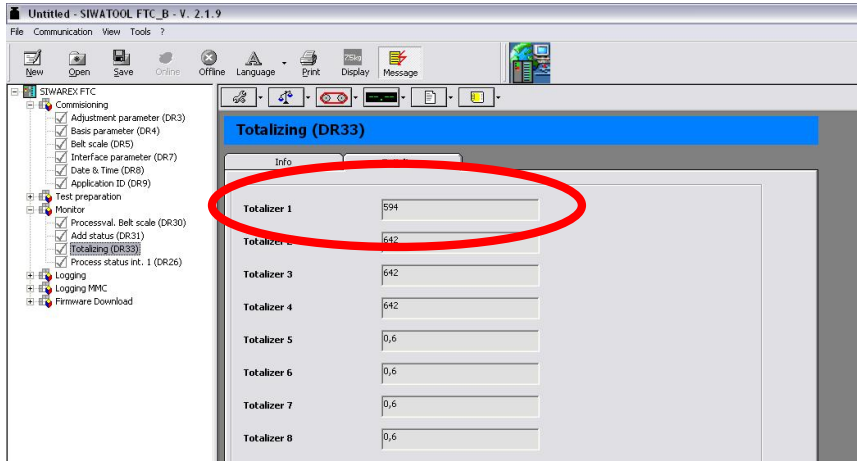

A value between 0.5 and 2.0 for the correction factor is possible.

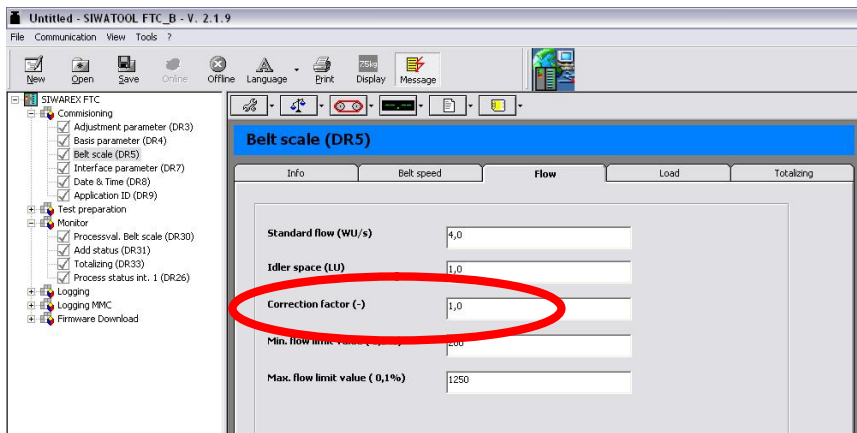

9 Back-up scale adjustments

Finally you may save the calibration data's into a file.
"Receive all data" assures adjustments from the SIWAREX FTA to the PC.
Otherwise the datas are only stored in SIWREX

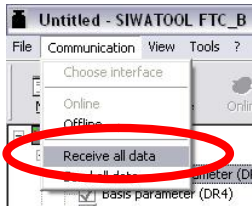

During the transmission from the Siwarex FTC module to the PC the following message appears:

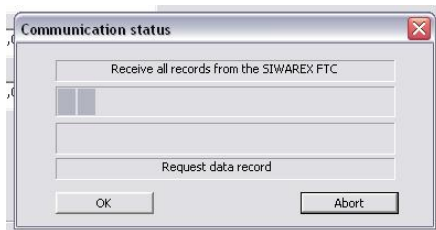

"Save as" a Siwatool FTC File:

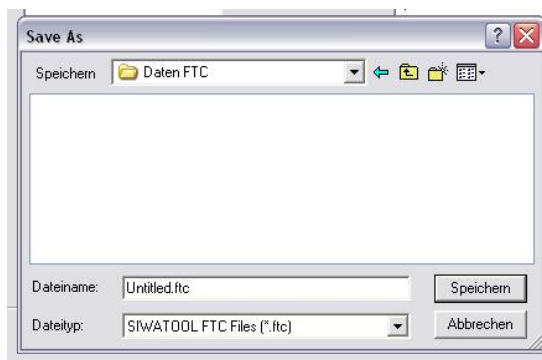
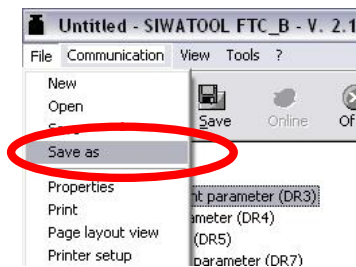

If you have any issues or suggestions regarding the related products or documents, please feel free to contact:

Technical support for SIWAREX:

Siemens AG
Industry Automation (IA)
Sensors and Communication
Process Instrumentation
D-76181 Karlsruhe
Germany

Tel: +49 721 595 2811

Fax: +49 721 595 2901

E-mail: hotline.siwarex@siemens.com

Website: www.siemens.com/siwarex

Copyright Statement

All rights reserved by Siemens AG

This document is subject to change without notice. Under no circumstances shall the content of this document be construed as an express or implied promise, guarantee (for any method, product or equipment) or implication by or from Siemens AG. Partial or full replication or translation of this document without written permission from Siemens AG is illegal.